



User Manual - L10 Pressure Lock Valve (UCM/A3 Valve)

Certified by TÜV SÜD Germany



1/2"



3/4"



1 1/2"



2"



2 1/2"



Warning: Only qualified personnel should adjust or service valves. Unauthorised manipulation may result in injury, loss of life or damage to equipment.

Prior to servicing internal parts, ensure that the electrical power is switched off, ball valve is closed and residual pressure in the valve is reduced to zero. Very high pressure spikes could result in deformation and oil splashing, this could cause serious injuries.

L10 Description: The L10 Pressure Lock Valve is a solenoid operated check valve designed for hydraulic elevators and includes a self closing manual lowering valve. Its purpose is to allow free flow of oil from the pump unit to the cylinder for upward travel and to prevent flow in the reverse direction from the cylinder to pump until an electrical signal is given to the solenoid. The L10 can be mounted in any position without causing any operational problems.

Installed in the main cylinder line directly adjacent to the main elevator control valve, the L10 can be employed as a safety back up valve to the down system of the main control valve to prevent unwanted down movement of the elevator should an electrical or mechanical malfunction occur in the main control valve (UCM case).

Another application of the L10 is to reduce the amount of bounce in a hydraulic elevator system due to the compressibility factor of oil between the cylinder and the control valve, by mounting the L10 directly onto the cylinder connection.

A Slack Rope Valve LK for roped elevators (e.g. 2:1 indirect transmission) is optional. It prevents the slack rope condition caused by the lowering of the ram when the car is suspended in the safeties or resting on the buffers.

| Technical Data: | 1/2" L10 | 3/4" L10 | 1 1/2" L10 | 2" L10 | 2 1/2" L10 |
|--|------------|----------|------------|--------|------------|
| Flow Range max.: | l/min 80 | 125 | 400 | 800 | 1400 |
| Operating Pressure min./max.: | bar 10-100 | 10-100 | 10-100 | 10-80 | 10-70 |
| Permitted operating pressure according AR 2014/33/EU | bar 10-100 | 10-100 | 10-59 | 12-59 | 10-59 |
| Burst Pressure: | bar 500 | 500 | 500 | 450 | 365 |
| Tank Connection for LH | TN 1/4" | 1/4" | 1/2" | 1/2" | 1/2" |
| Weight: | kg 0,8 | 1,4 | 2,5 | 4,2 | 7,0 |
| PB Cylinder pressure port: | G 1/4" | 1/4" | 1/4" | 1/4" | 1/4" |

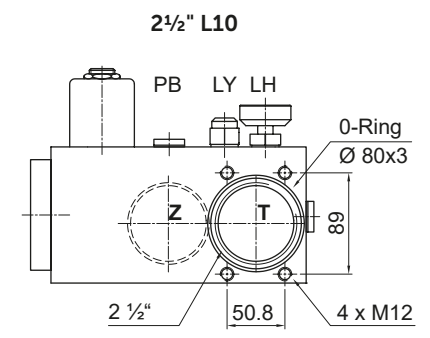
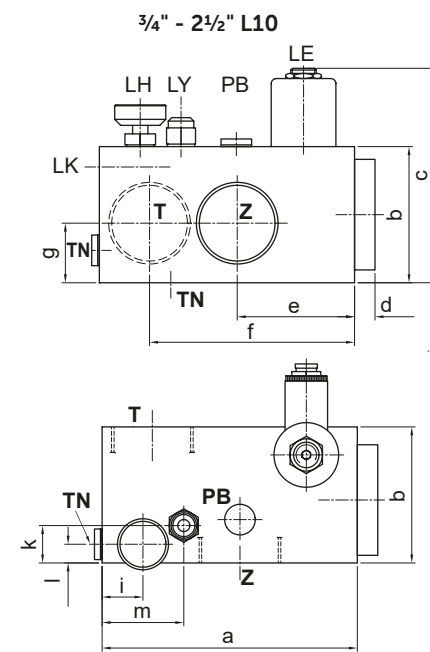
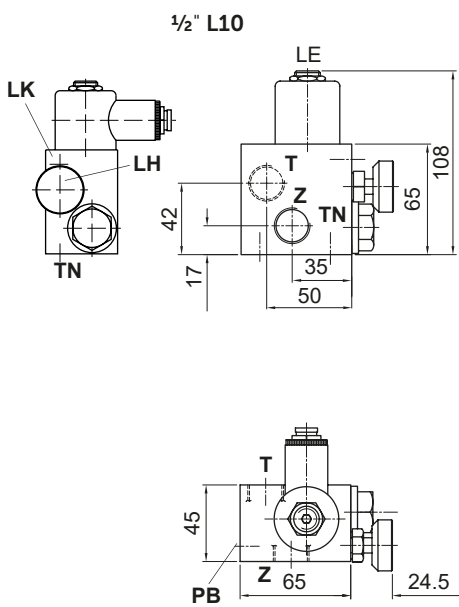

| L10 | 3/4" | 1 1/2" | 2" | 2 1/2" |
|-----|------|--------|-----|--------|
| a | 110 | 150 | 175 | 210 |
| b | 65 | 80 | 100 | 120 |
| c | 108 | 134 | 154 | 174 |
| d | 8 | 12 | 12 | 16 |
| e | 60 | 69 | 75 | 89 |
| f | 92 | 120 | 136 | 160 |
| g | 31 | 35 | 45 | 55 |

Attention: For manual lowering connect port TN with tank.

T→Z Free Flow. Solenoid LE not energized.
Z→T Flow only when Solenoid LE energized.

Blain Hydraulics GmbH Tel. +49 7131 28210
Pfaffenstrasse 1 Fax +49 7131 282199
74078 Heilbronn www.blain.de
Germany info@blain.de



GmbH

Designer and Manufacturer of the highest quality control valves & safety components for hydraulic elevators



Rest Position: When L10 is at stand-by, the solenoid **LE** de-energized and the main flow guide **LV** closed, preventing flow from cylinder to tank.

Up Travel: During up travel with the pump running, oil flows through port **T**, through the flow guide **LV** and out through port **Z** to the main cylinder. Solenoid **LE** is not energized.

Down Travel: For the car to have a down travel, the L10 should be energized approximately 0.5s earlier than the main control valve (e.g. EV100). This enables the oil to escape from the pilot chamber and allows the main piston **LV** to open. Else, the pressure between the L10 and the control valve connecting line drops considerably and to make the elevator operational, the connecting line needs to be re-pressurized again. This can be done by starting the elevator for a short time in the up direction or by pumping oil using a hand pump. Re-pressurizing may also be needed if the main control valve has an internal leakage. Opening of the **LV** allows the flow of oil from the cylinder to the tank (from **Z** to **T**) via the L10 and the main control valve.

The solenoid **LE** on the L10 valve is de-energized after the down solenoid of the main control valve (e.g. solenoid D of EV100). In this way, the piston **LV** in L10 and the down piston **X** in the main control valve closes completely.

Pressure drop: The pressure loss of the L10 valve depends on the size of the valve and the flow rate. The size and type of connectors used also influences the pressure losses. The pressure loss of the L10 valve should be taken into account while the main control valve empty car pressure is calculated.

Emergency down: The emergency manual lowering **LH** on the L10 is to be operated to bring the car down in emergency. The down speed of the car is determined by the setting of **LY**. As the LH is open, oil from the cylinder flows back to the tank through a return tank-line attached to the tank port **TN**. The return tank-line should not be smaller in size than the tank port **TN**, else the emergency manual lowering may not function properly.

The slack rope valve **LK** prevents the sinking of the RAM when the manual lowering **LH** is operated in a 2:1 roped elevator to prevent a tangled rope condition.

Air-bleed: After connecting the L10 valve or right after servicing the L10 valve needs to air-bleed to ensure its functionality. It is sufficient to operate the emergency lowering valve or loosening the solenoid tube slightly until oil is visible and tightening it again.

Adjustments

Manual Down Speed LY (3/4", 1 1/2", 2" and 2 1/2" valves): 'In' (clockwise) provides a slower, 'out' a faster down lowering speed.

Slack Rope Valve LK: The **LK** is adjusted with a 3 mm Allan Key by turning the screw **LK** 'in' for higher pressure and 'out' for lower pressure. With **LK** turned all the way 'in', then half a turn back out, the unloaded car should descend when the **LE** solenoid is energized. Should the car not descend, **LK** must be backed off until the car just begins to descend, then backed off a further half turn to ensure that with cold oil, the car can be lowered as required.

Functional test

In order to check the functionality of the L10 pressure lock valve, the solenoid **LE** can be de-energized during down travel. Alternatively the L10 can also be tested by unscrewing the retaining nut **MM** and manually lifting the solenoid coil **M**.

Caution! Once the coil **M** is removed from the solenoid tube **DR**, the energized coil will begin to overheat after about 10 seconds, holding it out longer may result in burning of solenoid coil.

The test may result in pressure drop in the connecting line between L10 and the control valve. In order to make the elevator operational, the connecting line needs to be pressurized again. This can be done by using the handpump to move the cabin over a small distance in up direction. Pressurising the line might also be necessary in cases where the pressure loss between the L10 and control valve is high for e.g. due to internal leakage.

| Status of lift | Power supply to coil of L10 |
|---------------------------------------|---|
| Up travel and releveling | power off |
| Down travel and releveling | power on |
| Stop with door closed | power can be switched off to save standby power |
| Unintended up travel with open doors | motor off once the movement sensor gets triggered |
| Unintended down travel with open door | power off once the movement sensor gets triggered |
| Emergency lowering | power on |
| Emergency manual lowering | manual actuation |
| Hand pump operation | power off |

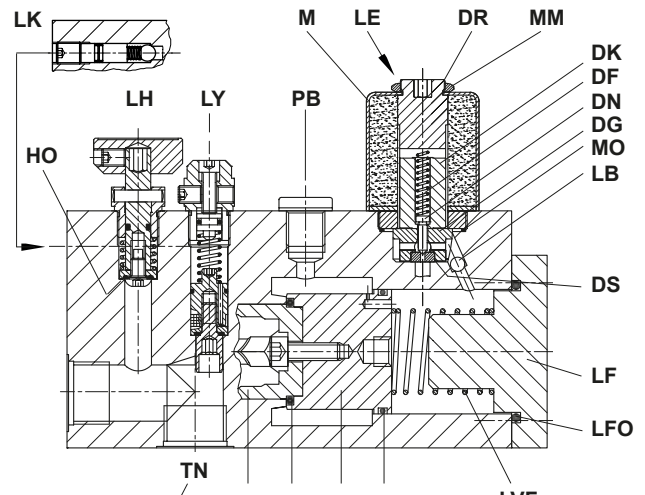

L10 1 1/2" - 2 1/2"
Do not reduce G 1/2" -
Use 1/2" tubing
(18 x 1,5)

Hydraulic Circuit

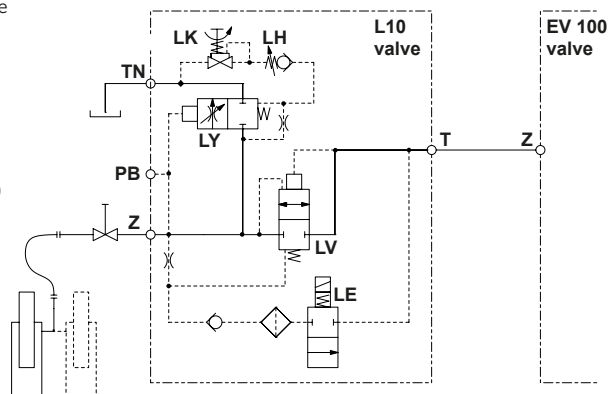

| No. | Parts List |
|-----|----------------------------------|
| LF | Flange |
| LFO | O-Ring- Flange |
| LB | Ball |
| LVF | Spring - Flow Guide |
| LFG | Flow Guide |
| LVO | Seal - Flow Guide |
| LVB | Body - Flow Guide |
| LUO | O-Ring - Flow Guide |
| LH | Manual Down - Self Closing |
| LY | Manual Down Speed Adjuster |
| HO | Seal - Manual Low. (5.28x1.78) |
| MM | Nut Solenoid |
| M | Coil Solenoid (indicate voltage) |
| DR | Tube - Solenoid |
| MO | O-Ring Solenoid |
| DF | Spring Solenoid |
| DN | Needle Solenoid |
| DK | Core Solenoid |
| DG | Seat Housing (with screen) |
| FD | Filter Solenoid |
| DS | Seat Solenoid |

Maintenance

Maintenance of the L10 is not necessary. Inspection of internal leakage should be done in regular intervals, at least once a year. If internal leakage has been detected, check the parts **DN**, **DS** and **FD** of the Solenoid **LE** first. Then inspect the O-rings of **LV**, **LY** and **LH**. The pressure of the valve has to be released before.

Control Elements

- LV** Check Valve
- LH** Manual Lowering
- LK** Slack Rope Valve (option)
- LE** Solenoid
- PB** Pressure Gauge (cylinder pressure)
- LY** Manual Down Speed Adjust. (not with 1/2" L10)

Connections

- T** Control Valve Connection
- Z** Cylinder Side Connection
- TN** Tank Return Line